



Excavator SWE 25F



Operating Weight	2.64t(rubber track)
Engine Power	14.6kW/2400rpm
Engine Brand	YANMAR
Standard Bucket Capacity	0.066m ³
Max. Digging Depth	2.705m

Excavator SWE25F

Parameter

ENGINE

Brand	YANMAR
Model	3TNV80F-SPSU
Type	3-cylinder 4-stroke water cooled
Displacement	1.267L
Power	14.6kW/2400rpm

DIMENSIONS

Counterweight Clearance	546mm
Tail Swing Radius	1050mm
Shipping Length	4262mm
Shipping Width	1500mm
Shipping Height	2400mm

ELECTRIC SYSTEM

Nominal Voltage	12V
Batteries	63Ah
Alternator	12V-40A
Starter	12V-1.7kW

WORKING RANGES

Max. Cutting Height	4445mm
Max. Loading Height	3110mm
Max. Digging Depth	2705mm
Max. Vertical Wall Digging Depth	2475mm
Max. Digging Reach	4845mm
Max. Reach at Ground Level	4715mm
Bucket Digging Force	24kN
Stick Digging Force	14kN
Ground Pressure	25kPa
Swing Speed	10rpm

DRIVE

Max. Travel Speed (2nd/1st)	4.4/2.6km/h
Gradeability	30°
Max. Traction	30.7kN

UNDERCARRIAGE

Undercarriage Width	1500mm
Shoe Width	300mm
Length to Center of Rollers	1560mm
Track Length	1990mm
Track Height	473mm

CAPACITY

Fuel Tank	42.5L
Hydraulic Tank	30L

BULLDOZING BOARD

independent moving, controlled by the gear shift lever	
Width X Height	1500X325mm
Max. Lifting Height	330mm
Max. Cutting Depth	320mm

HYDRAULIC SYSTEM

Main Pumps	
Type	2 variable displacement pumps, 1 gear pump
Displacement	2x28.8+19.2+6.5 L/min
Working Pressure	2x23.5+19 MPa

Excavator SWE 25F

Working Ranges

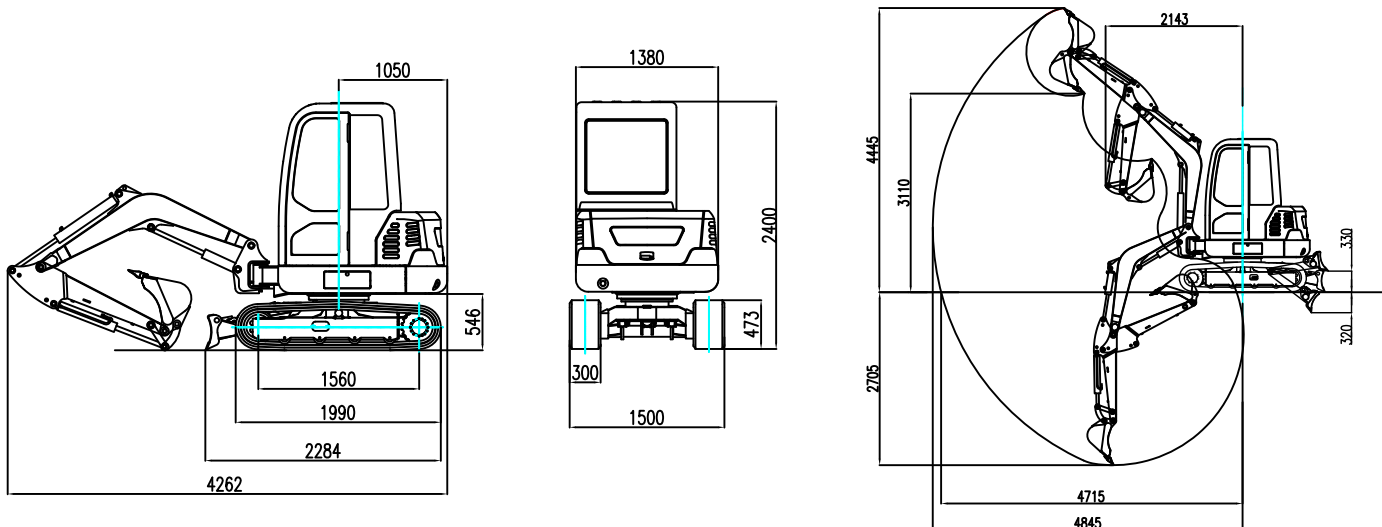

Load Capacity

A(m) \ B(m)	MAX.		3.0		2.0	
	Front (kg)	Side (kg)	Front (kg)	Side (kg)	Front (kg)	Side (kg)
3.0	469.00*	404.30	469.00*	404.30	–	–
1.0	555.10*	280.50	703.50*	396.10	–	–
0	612.60*	276.40	813.60*	358.90	1292.20*	598.20
-1.0	679.60*	363.10	679.60*	375.40	1005.00*	573.50

Notes:

- 1) Load with * is limited by hydraulic capacity and based on ISO 10567. Rated loads do not exceed 87% of hydraulic capacity.
- 2) Load without * is limited by tipping load and based on ISO 10567. Rated loads do not exceed 75% of tipping capacity.
- 3) The excavator bucket, hook, sling and other lifting accessories are not included in this table.



■ SUNWARD INTELLIGENT EQUIPMENT CO.,LTD.

Add: Sunward Intelligent Industrial Park, Xingsha, Changsha, 410100, China.

Tel: (0086-731) 83572 828 Fax: (0086-731) 83572 661

E-mail: international@sunward.com.cn

Web: www.sunward.com.cn

■ SUNWARD EUROPE HEAVY INDUSTRY NV

Add: Nijverheidspark 3, 3580 Beringen, Belgium

Tel: (0032-011) 434666

E-mail: eu@sunward.cc

